

Butler Memorial Hospital

Butler, PA



Building for the Future: A New Era Begins

James D. Rotunno

Thesis Proposal

Structural Option

Advisor: Dr. Ali Memari

Due December 11, 2009

Table of Contents

Executive Summary: 3

Introduction: 4

Structural System: Existing System 8

Design Standards & Codes: 12

 Design Load Summary: existing structure 13

Problem Statement: 13

Proposed Solution & Tasks: 16

Breadth Options: 17

Schedule of Proposed Tasks: 18

Conclusions: 19

Executive Summary:

The Butler Health System – New Inpatient Tower Addition/Remodel consists of approximately 206,000 square feet. The addition is adjacent but not connected to two previous additions and is situated in the inside north-west corner of the two existing structures. The structures are all separated by a six inch expansion joint.

The following report includes a description of the existing structural elements and force resisting systems which includes a composite deck and composite beam construction for the gravity system and braced frames for the lateral system.

A new gravity system is being proposed to reduce construction times and costs. With this new redesign the lateral force resisting system will have to be reexamined for a change in the controlling load case because of the redistribution of contributing loads since seismic and wind calculations from Technical Report #3 were so close together. The new design will consist of castellated built up girders with infill beams only at the intersection of columns. Research on the availability and fabrication of such members will have to be done for a final cost comparison as a comparable or viable option.

The two breadth options are both related to the redesigned system. The first being the construction management aspect of comparing the two systems costs and scheduling differences. If these cannot be reduced then the alternate system should be viewed as a non workable solution. Sound transmission between levels is examined as the second breadth, in particular the sound transmission between the first and second floor levels where there are conference and board rooms directly above chiller, mechanical, and boiler rooms. Alternative means of sound isolation will be investigated if levels are above acceptable levels. It is anticipated that the new design will reduce these levels below that of the existing design by the nature of the thicker anticipated 10” hollow planks versus the existing composite metal deck.

Introduction:

Butler Health System's new addition consists of two sub grade levels which have limited facade and entrances at ground level on the plan west end of the structure. There are five other at or above grade levels that comprise the bulk of the hospitals general facilities. One more final level, the penthouse level, encompasses the mechanical equipment on the roof top.

The structure is approximately 206,000 square feet with floor to floor heights of 14'-8" each. It stands at just a little over 100' tall above the highest grade level and is situated on the middle of a hillside. With the exception of the slightly arcing plan north facade the floor plan is quite regular with typical bay sizes being 28' x30'. This new addition is situated in the north-west corner of two existing additions to the hospital and is designed to have direct access into both parts. The additions are not directly connected to each other and are separated by a six inch expansion joint with all floor levels being at the same elevation.

Each level of the new addition has specific functions with the Ground and first floor levels being devoted to emergency generators, elevator pits, mechanical, electrical, boiler, chiller and storage rooms as well as some staff support areas. One quarter of the second floor area is given to training rooms, while approximately another quarter is seating / waiting areas; and the balance is given to an auditorium, chapel, physician lounges, a boardroom and conference rooms. Third floor space is devoted to the Ambulatory Care Unit, operating rooms and outpatient surgery. There is no fourth floor level. Fifth floor space is the Critical Care Unit and its support facilities. Floors six and seven are patient recovery rooms. On the top level of the structure is the penthouse level which houses the air handling units and mechanicals.

The design intent for the addition and renovations was to construct the building as economically feasible as possible and complete the renovations with as little disturbance to existing facilities and in the shortest time frame achievable. The need for this design intent was because of the need for deep drilled piers for the foundation system which took more time from the construction timeframe; therefore, construction time needed to be kept at a minimum and a cast in place concrete frame and flat plate system were eliminated as a construction type. A structural steel frame with composite beams and floor slabs with metal lateral bracing was decided upon. This type of structural system is consistent with the original and two existing additions.

Building Information Modeling was used throughout the design and construction process of this structure.



Figure 1: View looking from magnetic north

VICINITY MAP

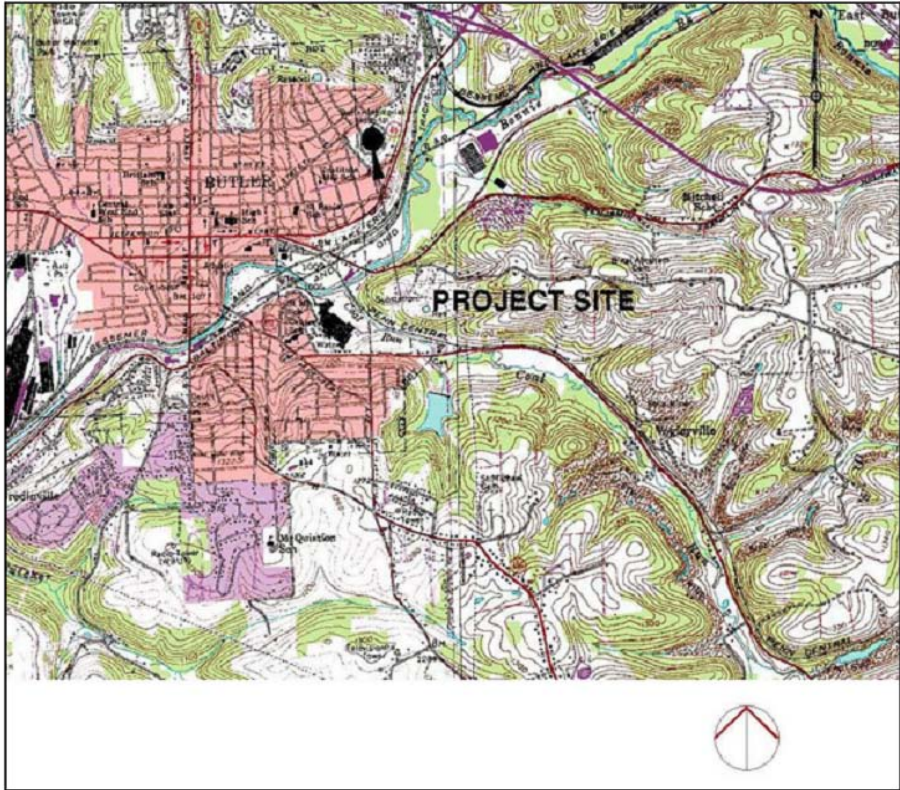

Figure 2: Location & vicinity map

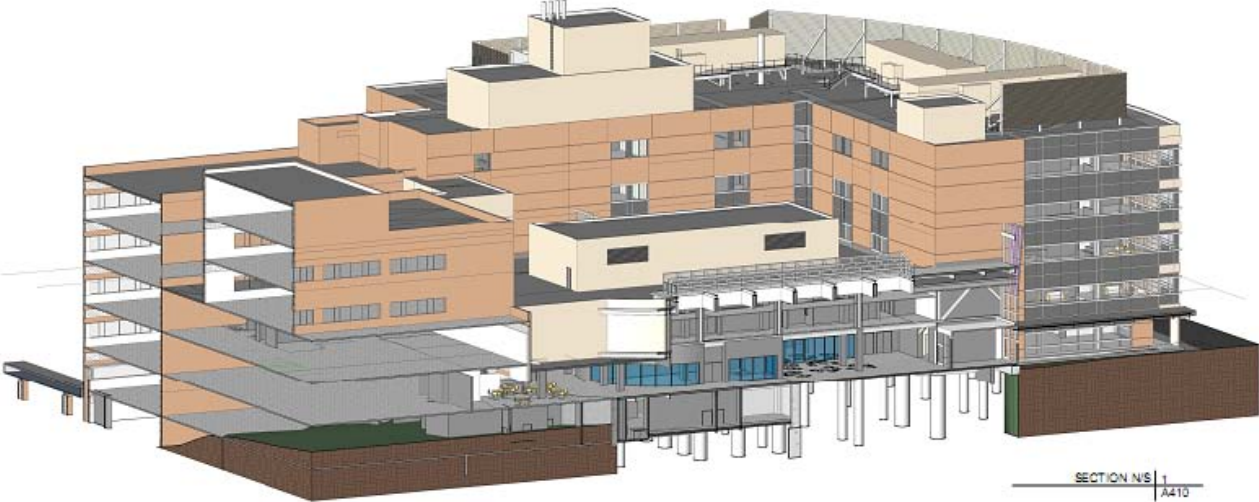

Figure 3: North-South Section

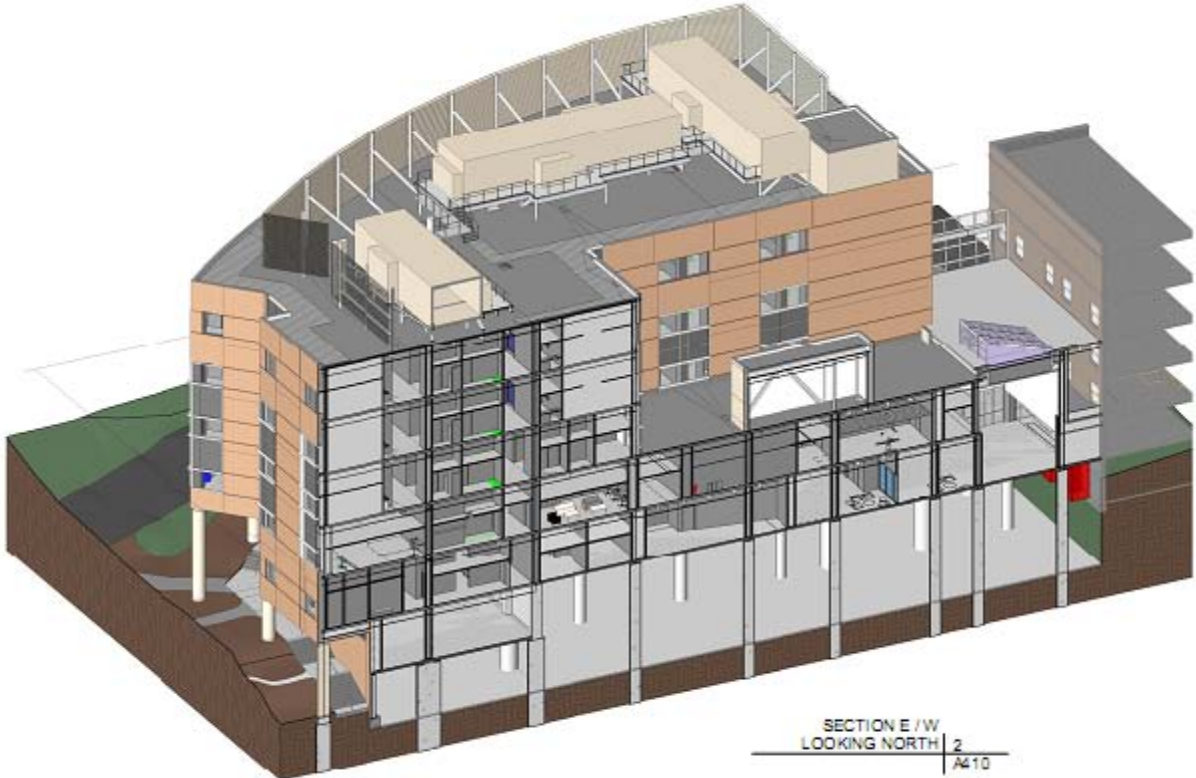

Figure 4: East-West Section



Figure 5: View of the North-West corner

Structural System: Existing System

Drilled caissons were used for the foundation system which range from 30” – 78” in diameter and reach depths of up to 79'. Grade beams between the caissons on the below grade level areas transfer wall loads to the foundation system and provide interior perimeter walls for the lower levels as well as provide support for the slab on grade at the second level. The piers have been designed for both end bearing and skin friction with an allowable end bearing pressure of 20 TSF and an allowable lateral earth pressure that varies with the depth of the soil strata from a minimum of 3TSf through fill and decomposed rock to a maximum of 12 TSF in the limestone/siltstone layer. They are comprised of 4000 psi @ 28 days strength concrete, ASTM A615 Grade 60 deformed bars with 12” minimum Class B tension lap splices where required and conform to ACI 318 design code.

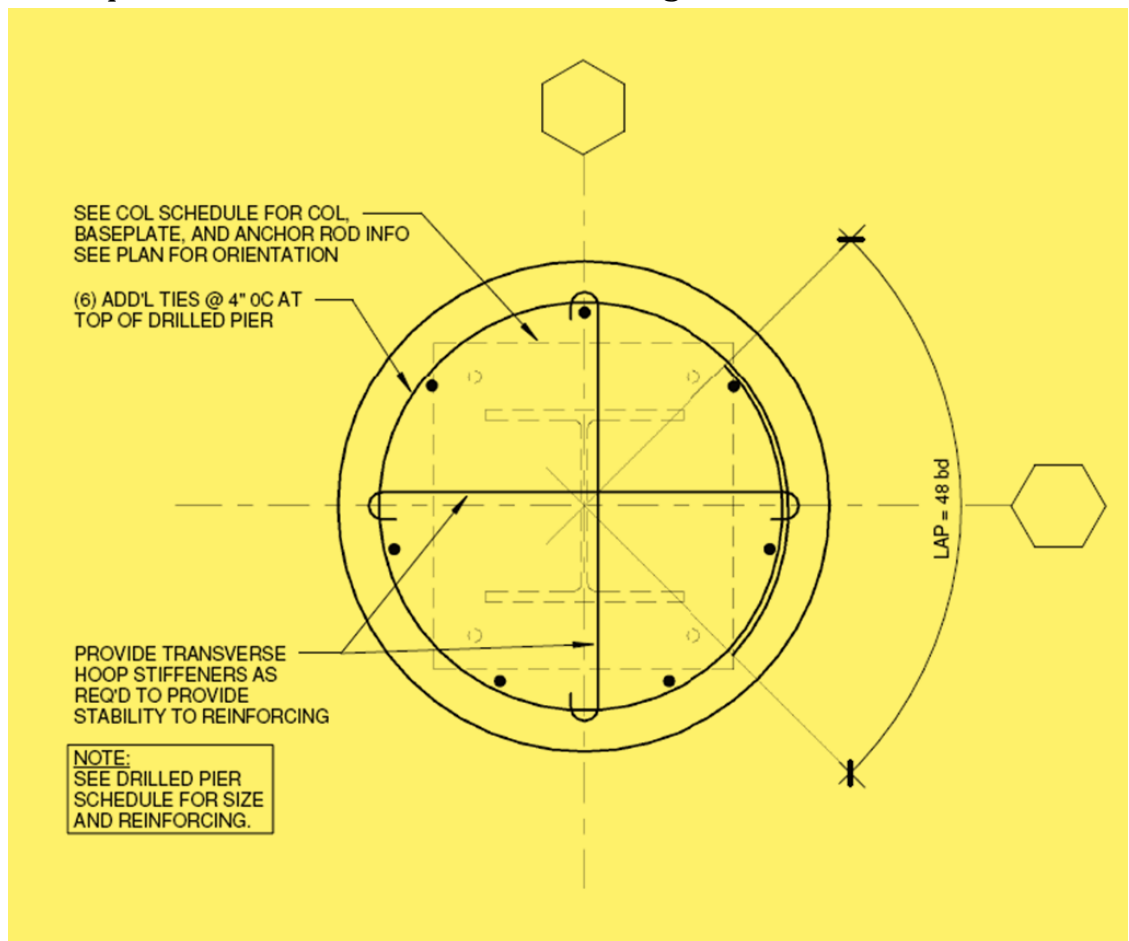

Figure 6: Typical drilled pier

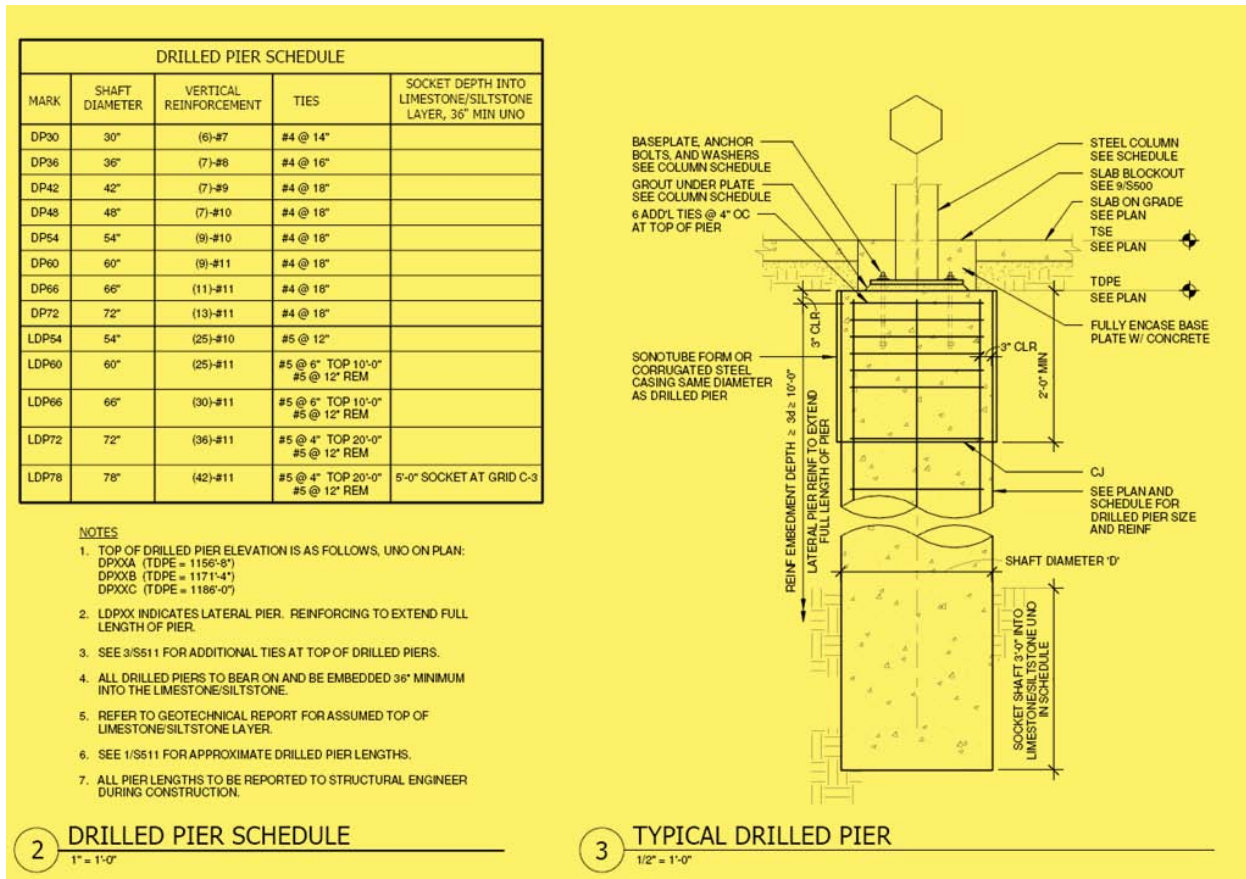

Figure 7: Drilled pier schedule

The superstructure is composed of steel W-shape members for the gravity load transfer components and steel HSS members in primarily an inverted chevron bracing pattern which provides the lateral force resisting system for the structure. Almost all member connections are shear connections with the exception of a few moment connections at cantilevering beams. These moment connections however do not contribute to the lateral force resisting system.

Floor systems are comprised of wide flange girders and beams supporting composite metal decking and composite concrete floor slabs. Floor thicknesses are 6-1/2" total with 3-1/2", 3500psi @ 28 day strength lightweight concrete and 5" shear stud length and either 6x6 WWF or #4 and #5 deformed bars @12" O.C.

All of the composite floor slab thicknesses are the same and all are supported by wide flanges with some being cambered to control deflections both during construction and while in service. All composite beams and composite decks are designed as unshored UNO as per construction document specifications. The size of pours between construction joints for concrete on metal deck is limited to 10000 square feet with a maximum dimension of 100 feet.

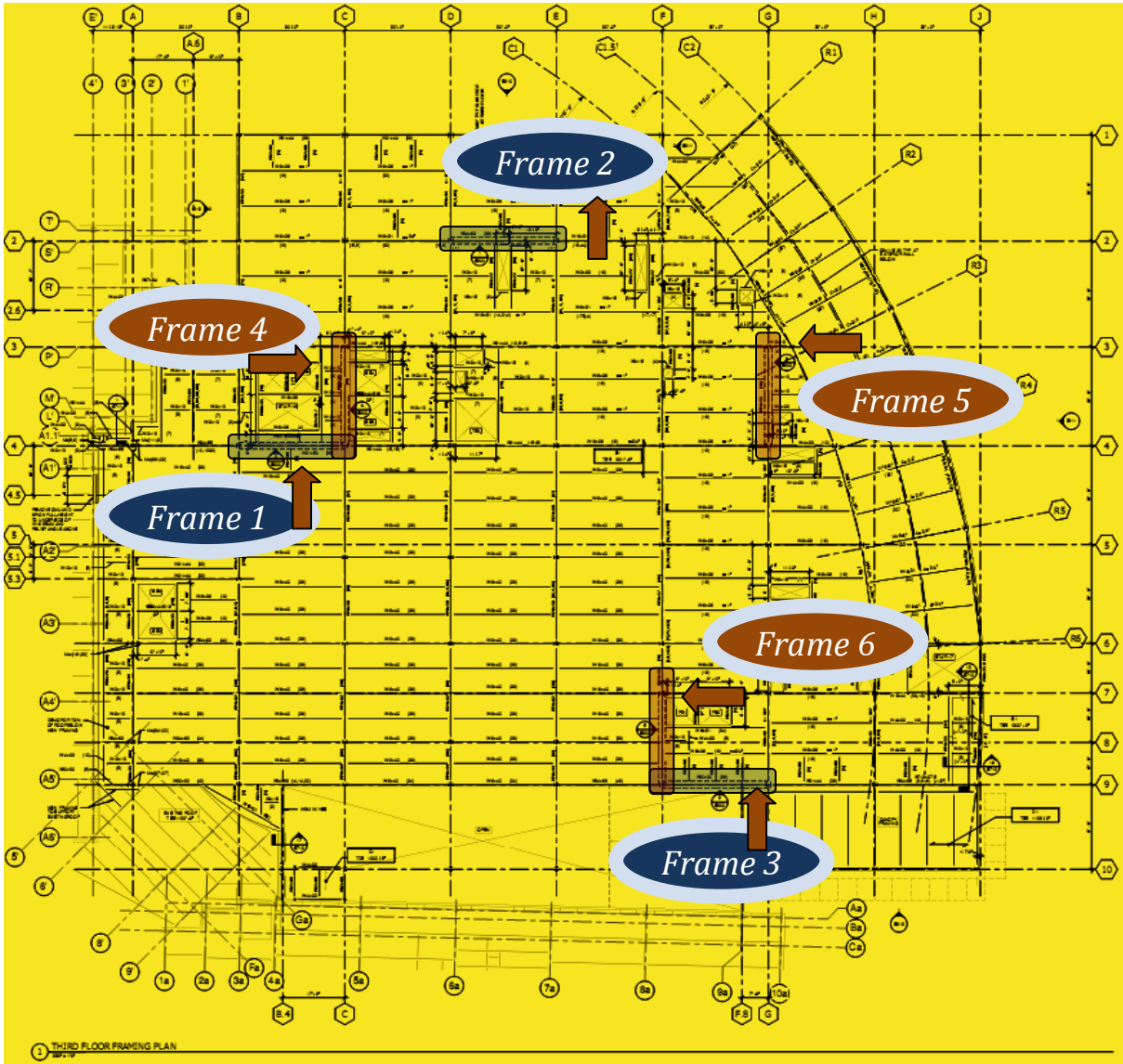

Figure 8: Third floor framing plan with braced frame locations shown. Typical bay sizes are 30'x30' or 30'x28'.

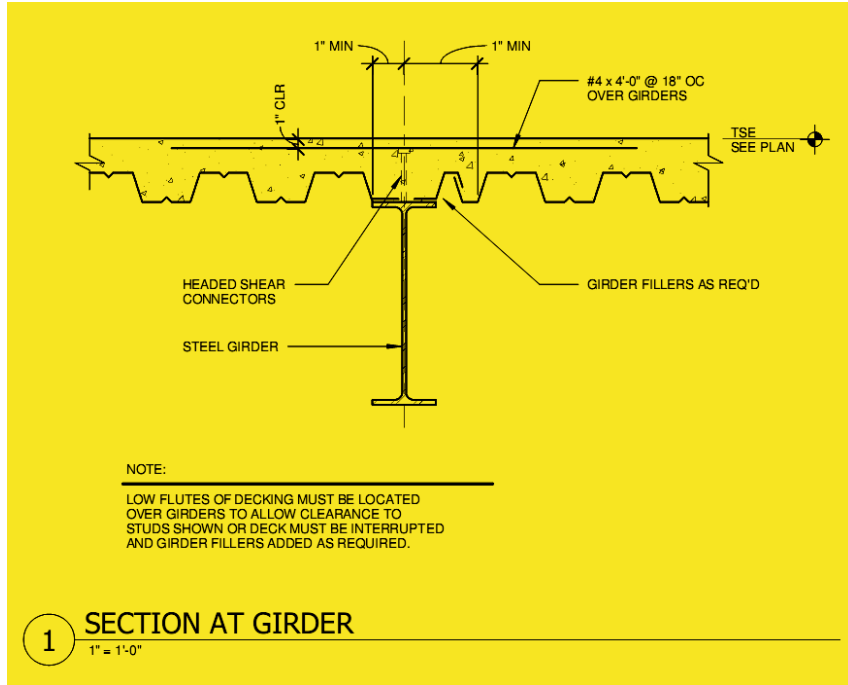

Figure 9: Existing slab & beam/girder conditions

SLAB/DECK SCHEDULE										
MARK	TOTAL THICKNESS	TYPE	DECK			CONCRETE		STUD LENGTH	REINFORCING	
			DEPTH	GAGE	FINISH	THICKN	TYPE		REINF	DETAIL
S1	6 1/2"	COMP DECK	3"	20	GALV	3 1/2"	LW	5"	WWF 6x6 W2.1xW2.1	
S2	6 1/2"	COMP DECK	3"	18	GALV	3 1/2"	LW	5"	#5 @ 12" OC T & B #4 @ 12" OC TRANSVERSE	
D1	3"	ROOF DECK	3"	20	GALV	-	-	-	-	

NOTES:

- ALL COMPOSITE SHEAR CONNECTORS (STUDS) ARE 3/4" Ø UNO.
- NW=NORMAL WEIGHT CONCRETE; LW=LIGHTWEIGHT CONCRETE.
- STUD LENGTHS ARE LENGTHS AFTER WELDING.
- SEE DETAILS 1,2,3/S701 FOR SLAB REINFORCING.
- SEE 14-16/S700 FOR DECK WELDING.
- SEE 17/S700 FOR COMPOSITE DECK STUD PLACEMENT.

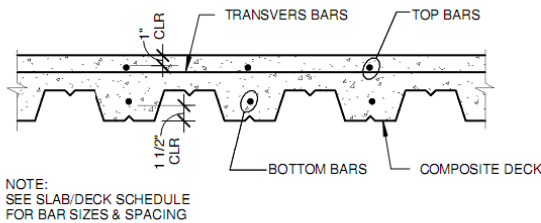

Figure 11: Slab/deck schedule

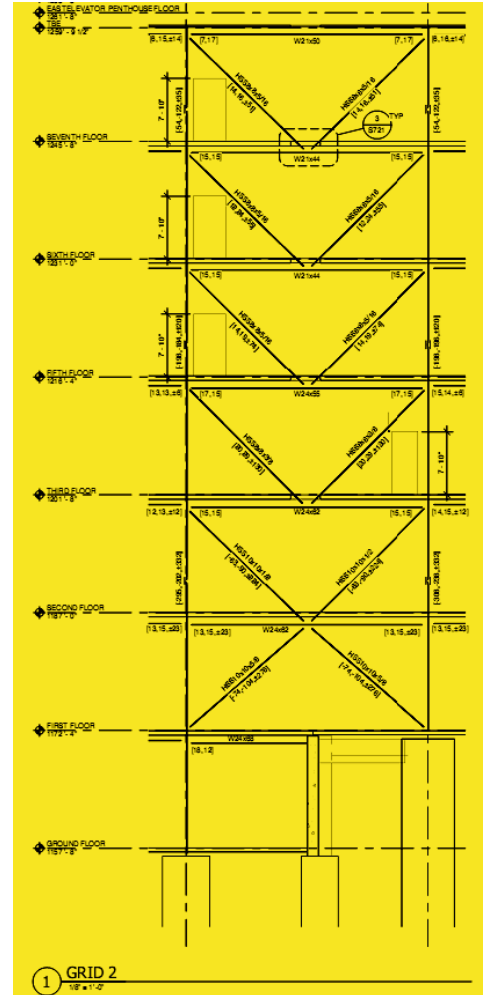

Figure 10: Typical lateral bracing elevation

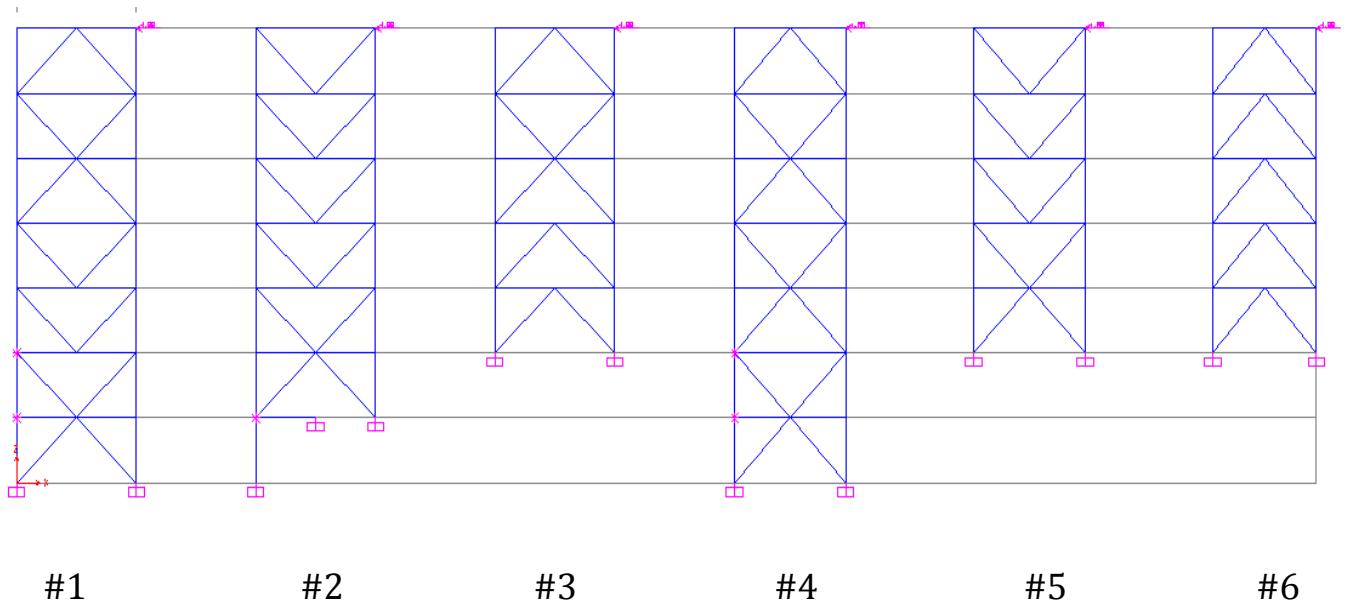

Figure 12: Lateral force Resisting System braced frames

Design Standards & Codes:

2006 IBC

2000 NFPA 101

2006 Guidelines for Design & Construction of Health Care Facilities

1998 Pennsylvania Department of Health Rules and Regulations for Hospitals

ASCE 7-05: for wind, seismic, snow and gravity loads

ACI 318-08: for concrete construction

AISC Thirteenth Edition: for steel members

Deflection criteria as per 2006 International Building Code:

Floor Deflections: $L/240$ for Total & $L/360$ for Live Load

Allowable building/story drift: $\Delta_{wind} = H/400$

Allowable story drift: $\Delta_{seismic} = 0.10h_{sx}$ (Table 12.12-1 ASCE 7-05)

Design Load Summary: for existing structure

Gravity Loads					
Description/location	DL/ LL	ASCE 7-05/ IBC 1607.9 values	HGA's values	Reduction available/used	Determined Design value
Concrete floors	DL	90-115pcf	115pcf	NO/NO	115pcf
MEP/partitions/finishes	SDL	20-25psf		NO/NO	25psf
1 st floor mechanical	LL		125psf	YES/NO	125psf
2 nd floor/ lobby	LL	100psf	100psf	YES/NO	100psf
Hospital floors	LL	40-80psf	80psf	YES/YES	80psf
Stairs & exits	LL	100psf	100psf	NO/NO	100psf
5 th floor roof	LL		115psf	NO/NO	115psf
Mech. Penthouse floor	LL		125psf	NO/NO	125psf
Elevator Machine room floor	LL		125psf	YES/NO	
Roof top equipment areas	LL		125psf (or actual equipment wt.)	NO/NO	125psf
Balconies	LL	100psf	100psf	YES/YES	psf
*Snow	LL	24-30psf	24-30psf	NO/NO	30psf

Figure 13: Design load comparison table

Problem Statement:

As in most structures being designed and constructed today the amount of time from concept to completion as well as the total built and operating costs of the structure are the main driving forces. The Butler Health System - New Inpatient Tower Addition/Remodel is not an exception. Therefore an alternative method of construction is to be investigated to try and reduce overall construction cost as well as maintaining or shortening the superstructure completion date.

Changing system types will also make it necessary to reanalyze the lateral force resisting system to verify which load combination will control since the factored base shear values in Technical Report #3 were within a maximum of 40 kips for seismic and wind.

As stated in the introduction, part of the design intent was originally to construct a two-way flat plate cast-in-place concrete floor system with integrated reinforced concrete columns and shear walls. As shown in the floor comparison summary table from Technical Report #2 this would have been an acceptable alternative and moderately less expensive system without taking the foundations into consideration (See comparison table Figure 14). However with the deep drilled pier foundation system being the most reasonable system to use based on the site conditions, the extra time taken to accomplish the foundation took away from the construction timeline; therefore a quicker alternative for the superstructure was decided upon.

Floor System Comparison of a Typical Bay				
Criteria	Floor systems			
	Existing Composite Steel	Steel Non-Composite	Concrete Two-way Flat-slab	Precast hollow-core concrete planks on steel beams
System weight (psf)	58	63	125	75
Slab depth (in)	6.5	5.5	10	10
Total depth (in)	28	32.5	18.5	27
Column size	W14	W14	24x24	W14
Fire rating (hr)	2	2	3	2
Additional Fire Proofing required	Yes	Yes	No	Yes
Column (cost/V.L.Ft)	161.20	185.65	105.00	161.20
Material (cost/sq.ft)	13.95	19.05	8.20	8.45
Labor (cost/sq.ft)	6.10	8.70	9.15	2.05
Total (cost/sq.ft)	181.25	213.40	122.35	171.70
Foundation impact	None	Minimal	Moderate	None
Constructability	Easy	Easy	Moderate	Easy
Vibration concerns	Some	Some	No	Some
Lateral force resisting system changes	N/A	No	Yes	No
Alternative	N/A	No	Yes	Yes
Additional study	N/A	No	Yes	Yes

Figure 14: Tech #2 comparison summary

An additional system that was investigated in Technical Report #2 was the precast hollow-core concrete planks on steel beams. The biggest drawback with this type of system is longer lead times for design and fabrication of girders and slabs;

however, if the impact of the foundation system is known from the start of the design process then an alternative superstructure such as this can be started earlier and some if not all of the lead time issues may be able to be averted.

Issues to be resolved with a proposed alternative redesign with the initial assumption that the foundation system type used is known from the start and is the only viable solution are:

- ✚ Can the construction time line be shortened versus the original design?
- ✚ Reduction of construction costs for the superstructure.
- ✚ Does the lateral system have to be changed, i.e. what controls? Will the overall weight of the structure increase/decrease?
- ✚ Will the redesign open up more space in the ceiling cavity for HVAC runs, sprinkler systems, plumbing, communication systems, pneumatic tube delivery system, bracing for equipment at ceiling height and aid in the building integration modeling process?
- ✚ Is the integration of existing exterior wall/cladding systems affected?
Connection to the proposed frame.
- ✚ Multiple different girders would have to be designed to carry the different loading conditions present, since none are commercially readily available.
- ✚ Can a girder be produced that will be shallow enough for the hollow-core planks and topping will work as in Figure 15? If so will they be able to carry all of the loads applied?

Proposed Solution & Tasks:

Alternative solution #2 as discussed on the previous page (the girder-slab system), as illustrated below in Figure 15, will be used as a system redesign.

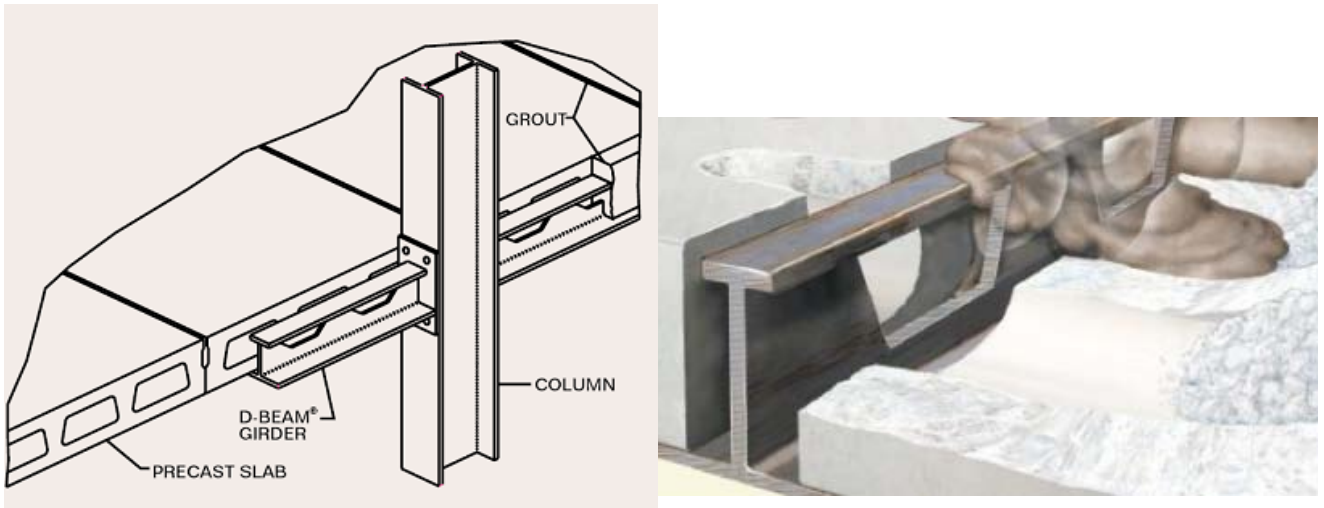

Figure 15: Modified castellated sections

Steps in the redesign process:

- ✚ Determine the design loads that the structure will be resisting both gravity and lateral per ASCE 7-05
- ✚ Configure the load path to be followed including which type of connections will be used between members
- ✚ Design of the hollow core planks to find the total depth required and the weight per square foot of the floor system
- ✚ Calculate the shape and size of the castellated girders needed to resist the shears and moments induced on them by the floor loading
- ✚ Assuming the use of the existing column sizes, calculate the total weight of the building.
- ✚ Compare the base shear values for wind and seismic, rework load combinations as per ASCE 7-05 and find which combination is the controlling combination.
- ✚ Distribution of lateral loads on the structure
- ✚ Size column girder and bracing members for total loads

- ✚ Generate a 3D computer model of the existing design and the redesign with calculated forces applied and evaluate comparisons
- ✚ Analyze the construction sequence and costs involved with both the original and redesigned systems and evaluate if there is any merit to changing the superstructure.

Breadth Options:

For the last task listed different sources and methods will be utilized other than just RS Means data values. Since the castellated girders are not normally used at this length and will have to be designed and fabricated to meet their special need consulting with the fabricator, designer/ other industry professionals would be a source of cost, time delay, or structural issues that may be encountered. Therefore a cost and time analysis of a typical level will be performed to evaluate the overall costs of the original and proposed revised floor system.

Option two involves a sound isolation study of the mechanical, chiller and boiler rooms which are located on the first level directly underneath the medical staff conference, conference, and board rooms on the second level. An evaluation of the existing system and the sound transmission levels will be compared to that of the proposed girder-slab system. It is expected that the new proposed system will reduce the sound transmission levels and make a quieter environment in these sound sensitive areas.

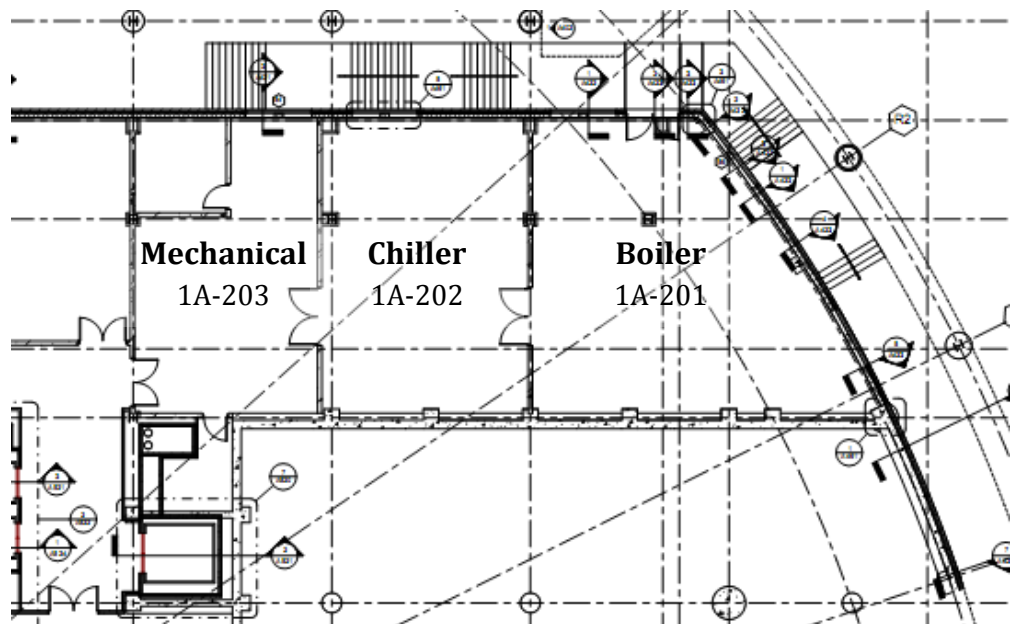
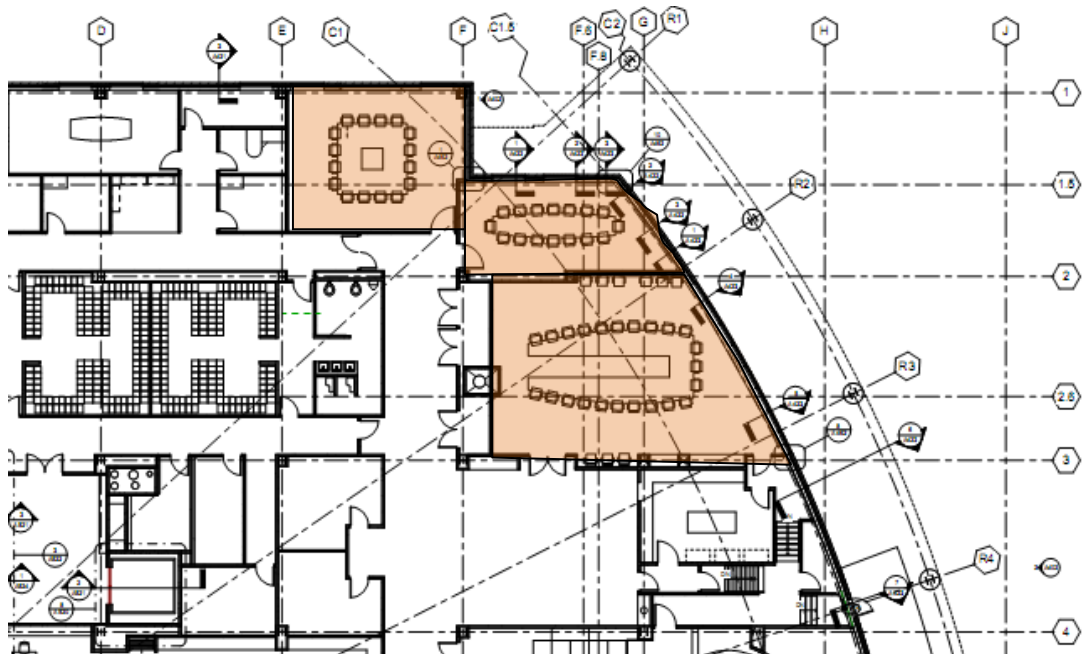

Figure 16: 1st level Mechanical room locations

Figure 16:
2nd floor
meeting room
locations



Schedule of Proposed Tasks:

Task	Weekly Schedule for January - February						
	1/10-1/16	1/17-1/23	1/24-30	1/31-2/6	2/7-2/13	2/14-2/20	2/21-2/27
System Investigations/Information Gathering							
Determination/Confirmation of Design Loads							
Hollow Core Plank Selection/Verification							
Castellated Girder Sizing and Calculations							
Recalculation of Lateral Loads and Controlling Combination							
Size and Confirm Framing Members for Total Loads							
Computer Model of Existing Structural System							
Computer Model of Proposed Solution							
Construction Sequencing & Cost Analysis							
Develop Presentation							

Task	Weekly Schedule for March - April							
	2/28-3/6	3/7-3/13	3/14-3/20	3/21-3/27	3/28-4/3	4/4-4/10	4/11-4/17	
System Investigations/Information Gathering		Spring Break					Presentations	
Determination/Confirmation of Design Loads								
Hollow Core Plank Selection/Verification								
Castellated Girder Sizing and Calculations								
Recalculation of Lateral Loads and Controlling Combination								
Size and Confirm Framing Members for Total Loads								
Computer Model of Existing Structural System								
Computer Model of Proposed Solution								
Construction Sequencing & Cost Analysis								
Develop Presentation								

Conclusions:

The Butler Health System – New Inpatient Tower Addition/Remodel was designed with construction time tables, costs and practicality as top priorities. In the following semester a redesign of the gravity system will be done with the purpose of offering an alternate design to shorten the construction schedule as well as overall associated superstructure costs. The design of the alternate gravity system, which will include the design of multiple castellated built up girders, will be analyzed to determine if the lateral system needs to be redesigned and if wind will still be the controlling lateral force over seismic. This system is normally not used in 28-30' spans. A 3D computer model of the existing design and the redesign will be done to compare designed as well as redesigned member sizes.

The two breadth options will be covered by an analysis of how the new floor system contributes to the overall sound transmission levels between sensitive areas (mechanical rooms and meeting rooms). The areas will be examined and results will be compared between the existing and redesigned system. Additional measures will be proposed if levels are found to be unacceptable.

The second breadth will be the cost analysis and construction timeline evaluation and comparison of the two systems to ultimately decide if the proposed redesign is a viable solution or alternative method.